



# Alpine Fire Protection District

1364 TAVERN RD. ALPINE, CA. 91901-3831  
BUSINESS (619)445-2635 • FAX (619)445-2634

## FARMERS MARKET AND COOKING BOOTHS AND VENDORS

Cooking Booths and Vendors using an open flame shall comply with the **2019 California Fire Code Edition.**

### **Chapter 31 Tents and other Membrane Structures**

**3103.8.2 Location.** Tents or membrane structures shall not be within 20 feet of *lot lines*, buildings, other tents or membrane structures, parked vehicles or internal combustion engines. For the purpose of determining required distances, support ropes and guy wires shall be considered as part of the temporary membrane structure or tent.

**3107.4 Open or Exposed flame.** Open flame or other devices emitting flame, fire or heat or any flammable or combustible liquids, gas, charcoal or other cooking device or any other unapproved devices shall not be permitted inside or located within 20 feet of the tent or membrane structures while open to the public unless *approved* by the *fire code official*.

**3107.12.5 Cooking Tents.** Tents with sidewalls or drops where cooking is performed shall be separated from other tents or membrane structures by a minimum of 20 feet.

**3107.12.6 Outdoor Cooking.** Outdoor cooking that produces sparks or grease laden vapors shall not be performed within 20 feet of a tent or membrane structure.

**Table 6104.3 Containers 500 gallons or less.** Portable LP-gas containers with a capacity of 500 gallons or less shall have a minimum separation between the container and structure not less than 10 feet.

**3107.13.3 Protection and security.** Portable LP-gas containers, piping, valves and fittings which are located outside and are being used to fuel equipment inside a tent or membrane structure shall be adequately protected to prevent tampering, damage by vehicles or other hazards and shall be located in an *approved* location. Portable LP-gas containers shall be securely fastened in place to prevent unauthorized movement.

# FARMERS VENDOR AND COOKING BOOTH LOCATIONS

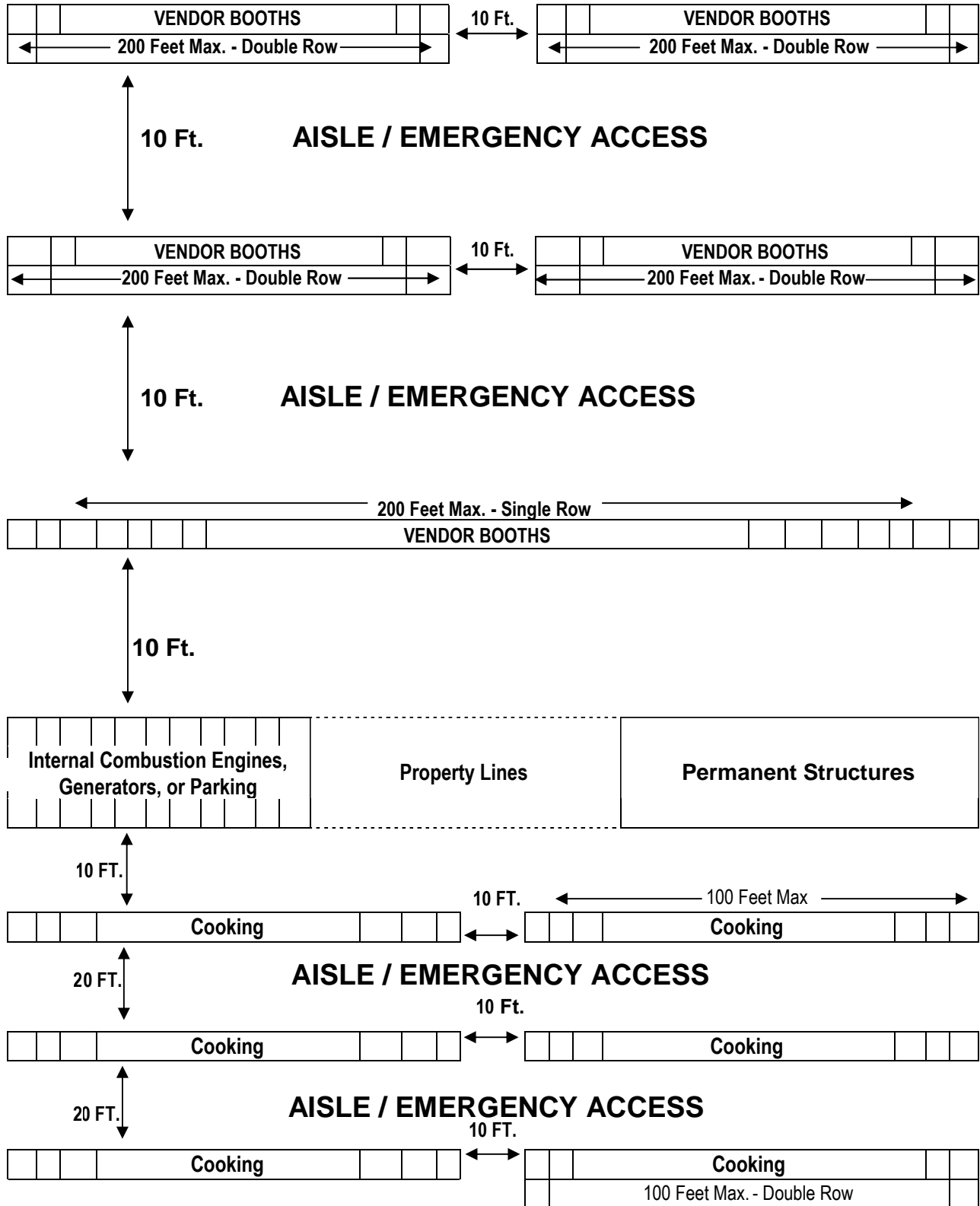

*Note: Cooking Booths are limited to single rows only.  
Back-to-back rows are not permitted. Maximum length of row is 100 feet.*

# Festival Cooking Booth

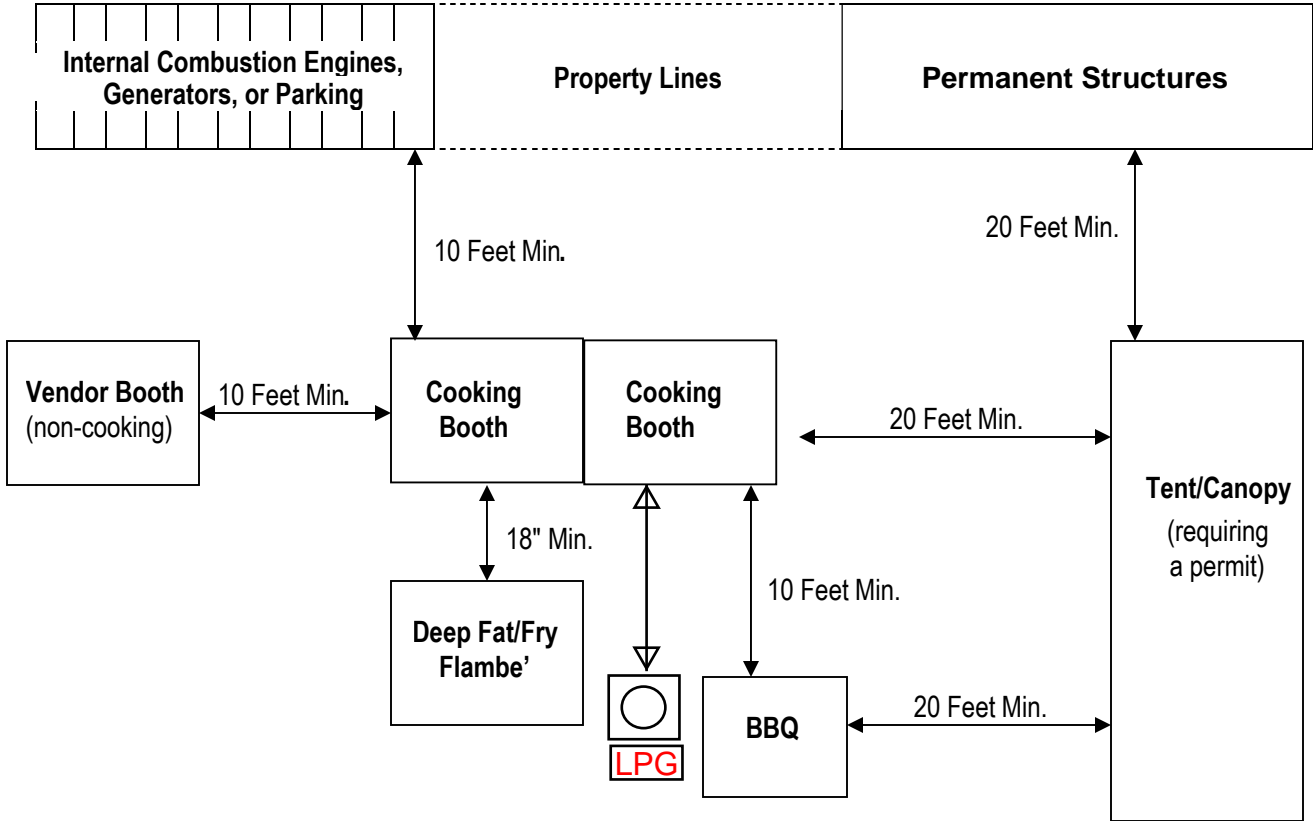
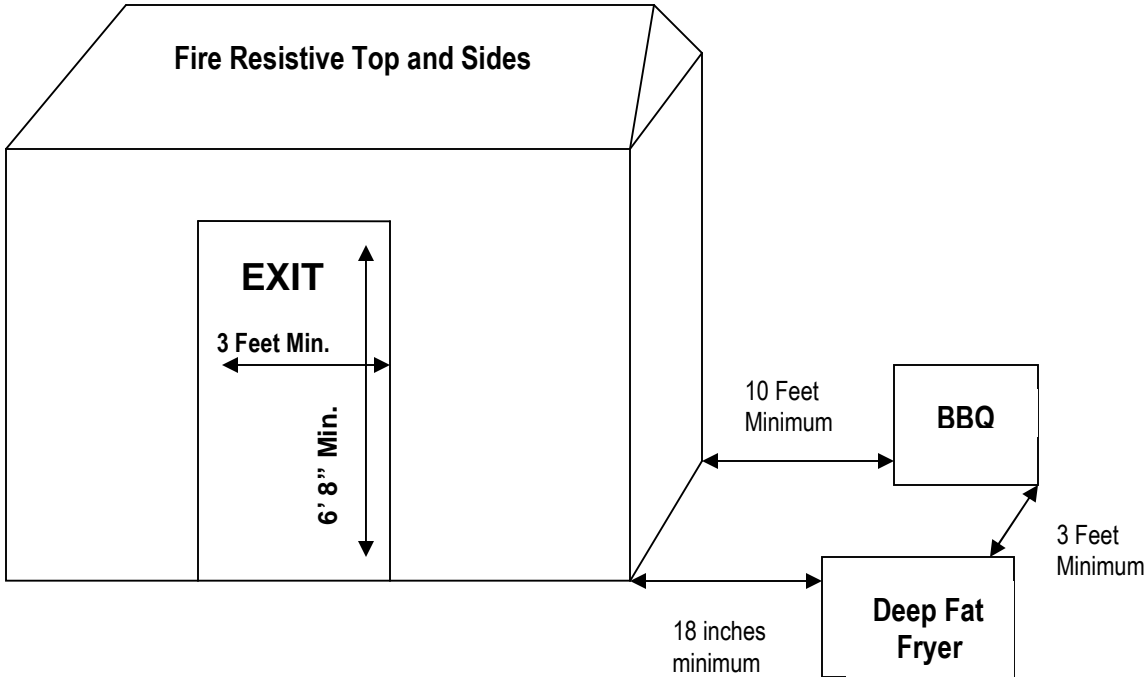

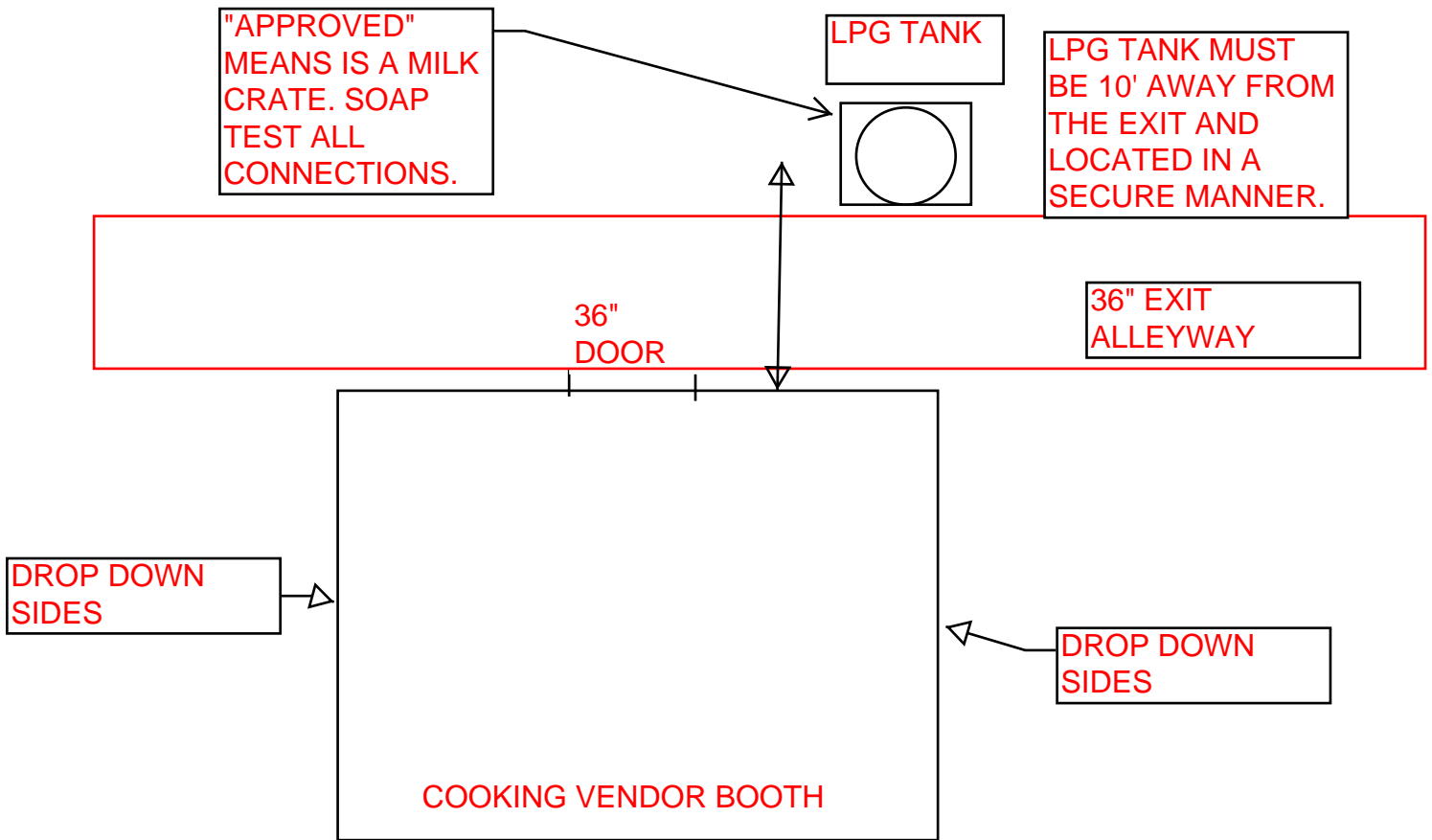

APPROVED COOKING BOOTHS SHALL BEAR THE INHERENTLY FLAME RETARDANT SEAL AND MUST BE CURRENT AS PER THE MANUFACTURES LISTING. ALL COOKING SURFACES AND TABLES SHALL BE NON-COMBUSTIBLE CONSTRUCTION. ANY TABLE WITH AN OPEN FLAME SHALL BE APPROVED AND NON COMBUSTIBLE. WARMING CHAFERS WITH "STENO" SHALL HAVE NON FLAMMABLE FABRIC TABLE CLOTHS AND NON COMBUSTIBLE ITEMS ON THAT TABLE.

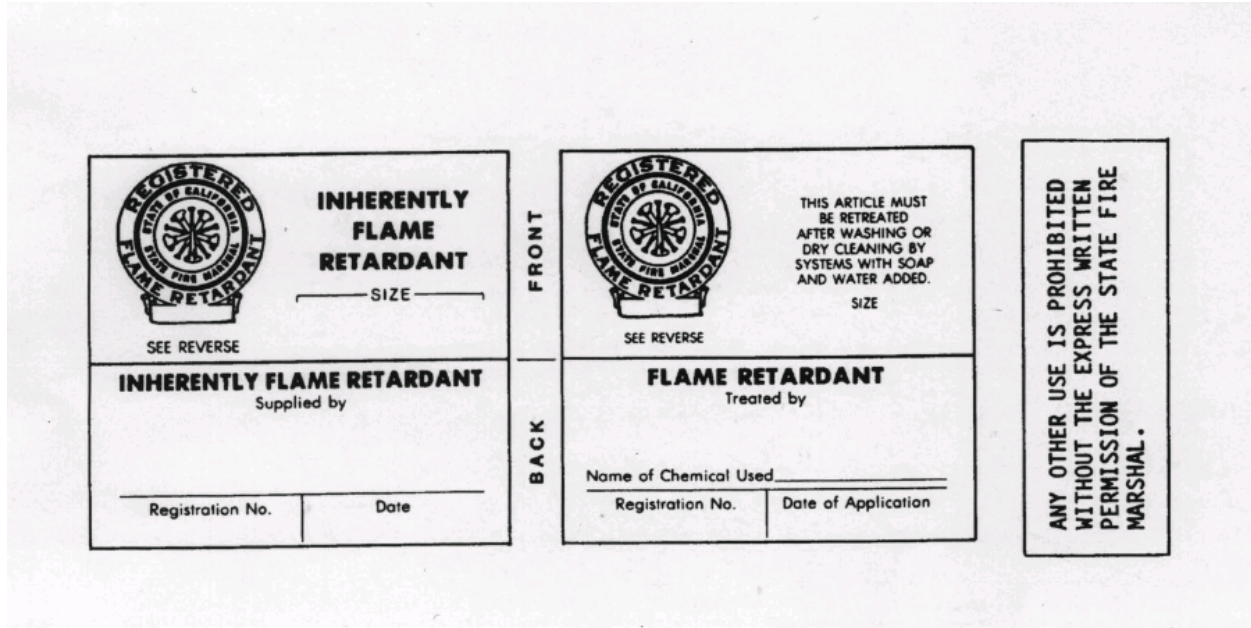



**ALPINE FIRE  
PROTECTION DISTRICT  
(619) 445-2635 •  
FAX (619)-445-2634**

**RESPONSIBLE VENDOR FORM FOR  
OUTDOOR COOKING BOOTHS**

Name of Vendor: \_\_\_\_\_

Mailing Address: \_\_\_\_\_

Telephone Number: \_\_\_\_\_

Type of Outdoor Cooking Booth: \_\_\_\_\_

\_\_\_\_\_

Date(s) of Function: \_\_\_\_\_

Location of Function: \_\_\_\_\_

I, \_\_\_\_\_ (*Print Name*) hereby represent and warrant that I am the authorized agent of \_\_\_\_\_ (*Print Name of Vendor*), with the authority to act on its behalf.

On behalf of said vendor, I have read and understood the Fire Department's Regulations for Outdoor Cooking Booths ("Regulations"), and I agree to comply with the Regulations at the location and on the date(s) specified above.

I understand and agree that the Fire Marshal (and/or representative thereof) may inspect said vendor's cooking booth at any time to enforce the Regulations.

I further understand and agree that said vendor shall be held liable for any and all fees and costs related to violations of the Regulations, as determined by the Fire Marshal, in the exercise of his/her sole discretion.

**READ, UNDERSTOOD, AND AGREED:**

\_\_\_\_\_  
Signature

\_\_\_\_\_  
Date

\_\_\_\_\_  
Name and Title

**Please return this completed form to: ALPINE FIRE PROTECTION DISTRICT**

1364 TAVERN ROAD  
ALPINE, CA. 91901