



ALPINE FIRE PROTECTION DISTRICT

FIRE PREVENTION POLICY MANUAL

REVISED

2/25/14

[Signature]

FIRE CHIEF APPROVAL

3-31-2014

EFFECTIVE DATE

STANDARD

PIV

1. POST INDICATOR CONTROL VALVE WINDOWS SHALL BE VISIBLE FROM 10' AWAY AT ALL TIMES. IF WINDOWS BECOME DEFACED OR CRACKED REPLACE ON ANNUAL SPRINKLER INSPECTION OR TITLE 19 FIVE YEAR SERVICE.
2. 36" OF UNOBSTRUCTED CLEARANCE SHALL BE TO ALL SIDES OF THE POST INDICATOR CONTROL VALVE AT ALL TIMES, UNLESS APPROVED BY THE FAHJ IN ADVANCE.

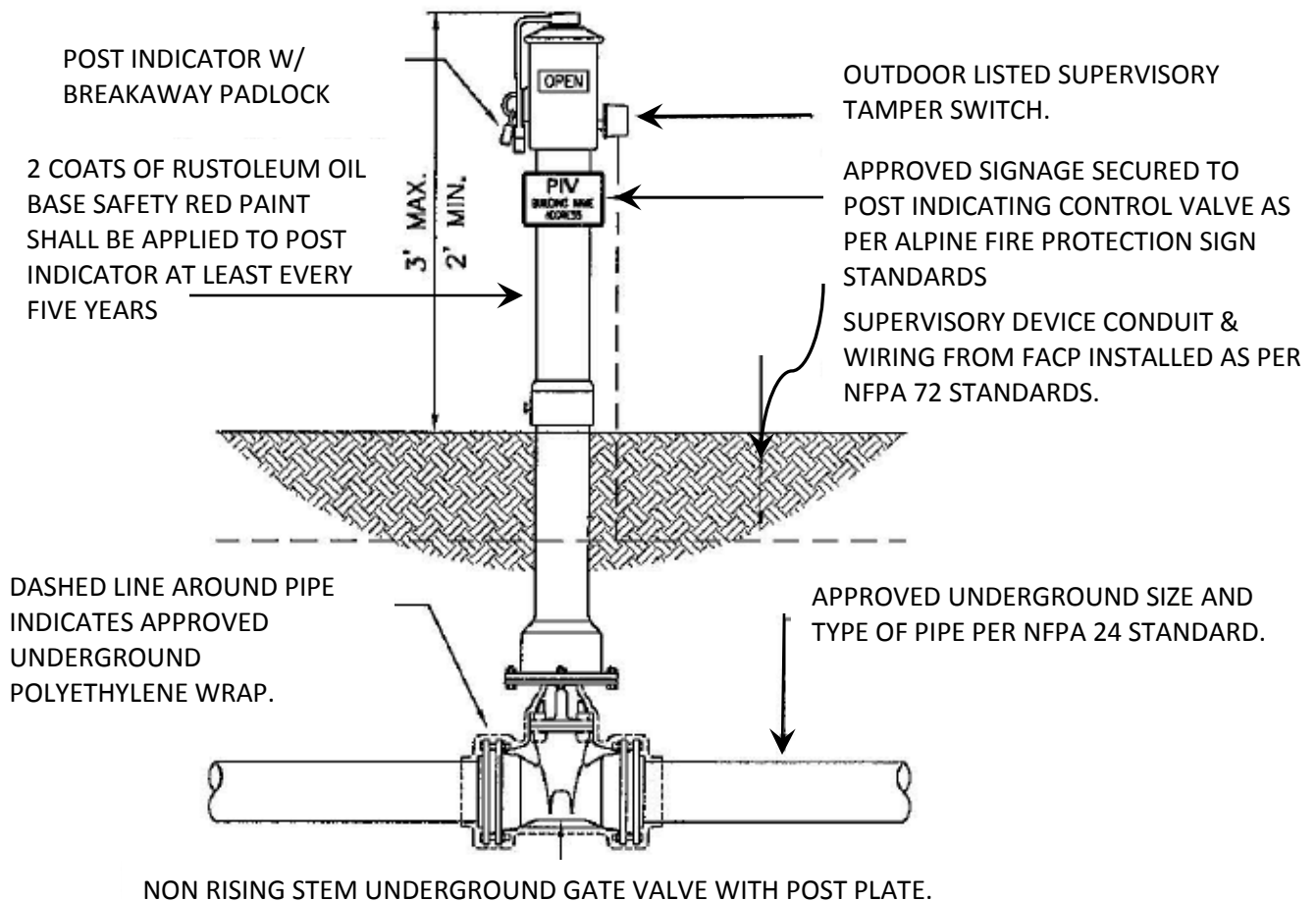

POST INDICATOR CONTROL VALVE